

3 PH FORWARD SEMICONDUCTOR MOTOR STARTER WITH DIRECT OVERLOAD

/SINGLE PHASE PROTECTION - CURRENT AND VOLTAGE DETECTION

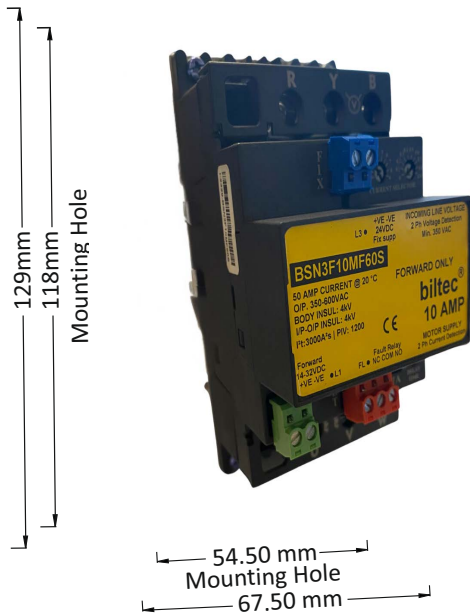

TYPE "D-67.50"
 Model 301- 1 Nos.
 Current upto 36Amp @40°C with Din Rail 45mm
 $\Delta T = 75^\circ C$
 Surface Area:
 750mm² X 67.50mm = 50625 mm³
 67.50mm(W) X 130mm(L) X 15mm(H) + SSR
 Weight : @ 135gms

APPLICATIONS:

- LAMINATION EXTRUSION
- ACTUATORS
- CNC MACHINES
- CRANE MOTOR
- VMC MACHINES
- HMC MACHINES
- VTL MACHINES
- HTL MACHINES

ADVANTAGES :

- ❖ Over load current setting by linear POT.
- ❖ Output will be OFF during any Fault conditions like Current Overload, Single Phasing, Input Phase Failure, Phase Unbalance, Locked Rotor/shaft, Earth Fault.
- ❖ Single module for Forward control of 3 phase motor with inbuilt motor protection via current and voltage detection
- ❖ No need to use external bimetallic overload relay or MPCB protection
- ❖ No require any external snubber or MOV at Input and Output side
- ❖ Common Max. 10 Amp 3Ph M.C.B. for cut off Power Supply line and Initial Short circuit Protection
- ❖ Push to reset when fault is Present
- ❖ Very compact design which occupies less space and has easy panel wiring
- ❖ Remote fault indication via mechanical changeover relay
- ❖ Starting delay timer can solve locked rotor/shaft problem.
- ❖ Motor Output will be OFF if there is current inrush after fixed starting delay time.
- ❖ For any Fault, when current exceeds output will be OFF within 50 ms
- ❖ SSR ON/OFF at Zero crossover, MTBF 10¹¹, switching time 10ms, No arcing.
- ❖ Do not face any harmonics noise problems in control circuit which generated by AC drives/servo drive
- ❖ Input Control Voltage can give directly from PLC, No need of Mechanical Relay.
- ❖ No need to use MPCB.
- ❖ No need to use 2 CONTACTORS FOR FW/REV + AUXILIARY ADD ON BLOCK CONTROL + OVERLOAD RELAY Locked Rotor/shaft, Earth Fault.

Fault condition	SSR Output	Fault red LED indication	Fault Mechanical Relay Change Over
Current Overload	OFF	YES	YES
Single Phasing	OFF	YES	YES
Input Phase Failure	OFF	YES	YES
Phase Unbalance	OFF	YES	YES
Locked Rotor / Shaft	OFF	YES	YES
Earth Fault	OFF	YES	YES

ORDERING FORMAT

DOLSP : Direct Overload Single Phase Protection
Output Voltage 60: 350-600 VAC
Control Input 01 : 14-32 VDC

Output Current Rating 05,10,15
Over DC Input TO AC Output

EXAMPLES
 BSN3F10MF60S

NOTE 1 : Available for 05,10,15Amp with Auto & Manual Reset Switch.
NOTE 2 : Optional 5-32 VDC Control Input can be available.

OVER CURRENT SELECTOR POT INDICATION

5 Amp Selection : LHS (0.5 to 5)

10 Amp Selection : LHS (0 to 10) + RHS (0.1 to 0.9)

15 Amp Selection : LHS (1.5 to 13.5) + RHS (0.15 to 1.35)

STARTING DELAY TIME POT

7 9 11 13
5 15
3 17
0.2 20

0.20 To 20 Seconds

MANUAL ON
MANUAL/AUTO RESET SWITCH
AUTO TIME: 18 Seconds

PUSH TO RESET
 Output will be latched for any fault condition and reset after pressing these reset button for 24 VDC fix Supply ON/OFF.

SSR SELECTION FOR 3 PHASE MOTOR (INDUCTIVE LOAD)

BSN3F MODEL	HP / kW Rating	05 AMP	10 AMP	15 AMP
	HP Rating	Upto 3	Upto 5	Upto 7.5
	kW Rating	Upto 2.2	Upto 3.7	Upto 5.5

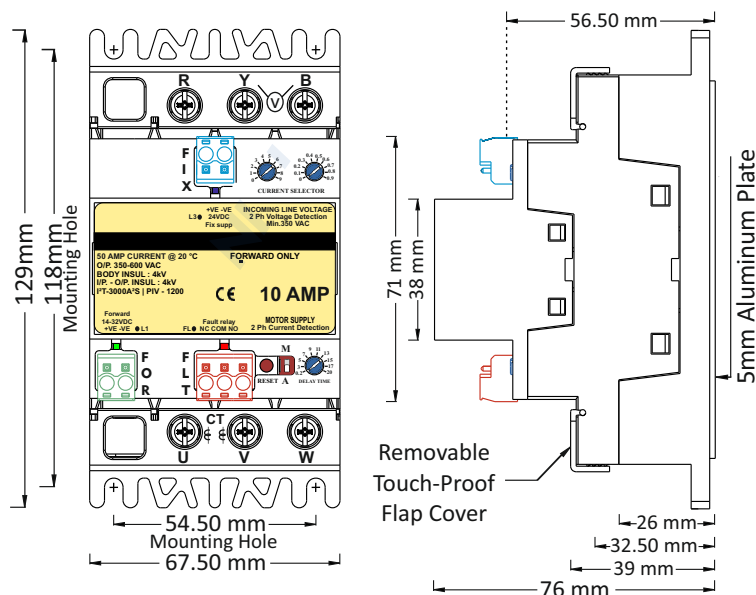



General Specification	
Max Barrier Layer Temperature (T _{max})	< 125 °C
Ambient Temperature Range (T _{amb})	0-85 °C
SSR Storage Temperature Range (T _{st})	-40°C to 80°C
Input Terminal Screw Torque Range	τ = 0.5 N.m (Max.)
Output Terminal Screw Torque Range	τ = 2.5 N.m (Max.)
Power Factor COSφ @Max. Load @480VAC	> 0.55
Housing Material	UL-94 V0 Grade
Base Plate	Aluminium
SSR Weight	> 430 grams
Control Input Electrical Wire Size (Max.)	Up to 2.1 sq mm(14 AWG)
Power Output Electrical Wire Size (Max.)	Up to 25 sq mm(3 AWG)
Test Standards:	ROHS,IP20
Pollution Degree	3

Input Technical Specifications		
Parameters	Unit	ZDA
Forward Control Voltage Range (V _c)	V	14-32VDC
Control Supply Current Consumption	mA	5-6mA
Input Forward Surge voltage Protection V _{PK}	VAC/VDC	325VAC/DC
Fix Supply Voltage (V _s)	VDC	23-24 VDC
Fix Supply Current Consumption	mA	45 mA
Fix Supply Voltage Surge Protection	VDC	80 VDC
Input Impedance (Current Regulator Circuit Impedance)	Ω	2 kΩ - 5 kΩ
Minimum Turn ON Voltage(V _{ON})	VDC	13.5 VDC
Turn OFF Voltage(V _{OFF})	VDC	< 13 VDC
Forward Control Input Status	-	GREEN LED
Maximum Turn ON Time	mS	≤ 1/2 Cycle(10 mS)
Maximum Turn OFF Time	mS	≤ 1/2 Cycle(10 mS)

	FORWARD	FIX SUPPLY	FAULT
LED INDICATION	● GREEN	● BLUE	● RED

Output Technical Specifications @ 25°C Unless Specified					
Parameters	Symbol	Unit	05 Amp	10 Amp	15 Amp
Rated Operational Voltage	U _e	V _{RMS}	350-600 VAC BACK TO BACK SCR		
Operating Frequency Range	f	Hz	47-63 Hz		
Peak Inverse Voltage	PIV	V _{PK}	1200	1200	1200
Max. Surge Voltage With Stand Capacity (<1 Second) (U _s)	V _{surge}	V _{RMS}	2700 V _{RMS} (3800 V _{PK})		
Rated Operational Current AC53a @ 40°C(Inductive Load-Motor)	I _e	Amp	5	10	15
Rated Operational Current AC53a @ 20°C	I _T	Amp	40	60	90
Maximum 3 Phase Motor Rating	hp kW	hp kW	3 hp 2.2	5 hp 3.7	7.5 hp 5.5
NON Repetitive Surge Peak ON-State Current @ Rated V _{RRM} applied for 1/2 Cycle t=10 mS/ t=8.33 mS (50 Hz/60 Hz)	I _{TSM} @ 50 Hz I _{TSM} @ 60 Hz	A _p	460 490	800 840	1200 1260
Max. I ² t for Fusing @ t=10 mS (50Hz)	I ² t	A ² s	1060	3000	7200
Max. I ² t for Fusing @ t=8.33 mS (60Hz)	I ² t	A ² s	996	2750	6510
Max. Peak ON-state voltage Drop	V _{TM}	V _{RMS}	≤ 1.2	≤ 1.2	≤ 1.2
Min. Isolation Resistance between F-R Input Terminals (-R1,+R2) & (-F1,+F2) to Output Terminals R,Y,B,U,V,W) @ 500 VDC	Ω	GΩ	50	50	50
Isolation Voltage F-R Input Terminals (-R1,+R2) & (-F1,+F2) to Output Terminals (R,Y,B,U,V,W) for 1 Minute (U _{imp})	V _{ISO}	kV	4	4	4
Isolation Voltage I/P & O/P Terminal (-R1,+R2,-F1,+F2,R,Y,B,U,V,W) to Body Isolation for 1 Minute(U _{imp})	V _{ISO}	kV	4	4	4
Max. Rate of Rise OFF-State Voltage	dV/dt	V/μS	1000	1000	1000
Max. Rate of Rise OFF-State Current	di/dt	A/μS	50	150	150
Max. Peak Repetitive Forward OFF-State Voltage	V _{DRM}	V	1200	1200	1200
OFF State SSR Leakage Current @ Rated Voltage & Frequency (Snubber Leakage)(I _l)	I _{leak}	mA	< 2 mA	< 2 mA	< 2 mA
SCCR Current Rating	I _{SCCR}	kA	-	10 kA	10 kA
SSR Weight	W	gram	470	470	470
Output Fault Indication	Red LED & Mechanical Relay change over 230 VAC-1Amp or Optocoupler output				

Output power terminal specification		
Connector Type	Connector Visuals	Connection capacity
Push Type		<ul style="list-style-type: none"> 0.2 TO 2.5 SQ MM WITH PIN TYPE BOOTLESS LUGS OF LENGTH 10 MM 4 SQ MM BARE COPPER WIRE – MULTI CORE OR SINGLE CORE
Screw Washer		<ul style="list-style-type: none"> 0.5 TO 10 SQ MM WITH PIN TYPE BOOTLESS LUGS 16 TO 25 SQ MM (6mm Diameter) ROUND TYPE LUGS, For Example 16-6 etc... 1.5 TO 2.5 SQ MM U-TYPE LUGS

Circuit Diagram- BSN3F MODEL

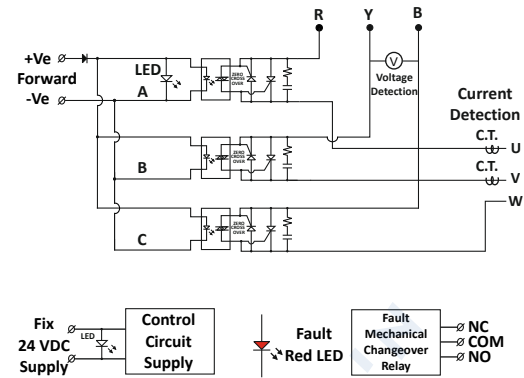

3F
FIRE RETARDANT PLASTIC

3 PH FORWARD SEMICONDUCTOR MOTOR STATER

WITH EXTERNAL SHORT CIRCUIT PROTECTION DEVICE CONNECTION DIAGRAM

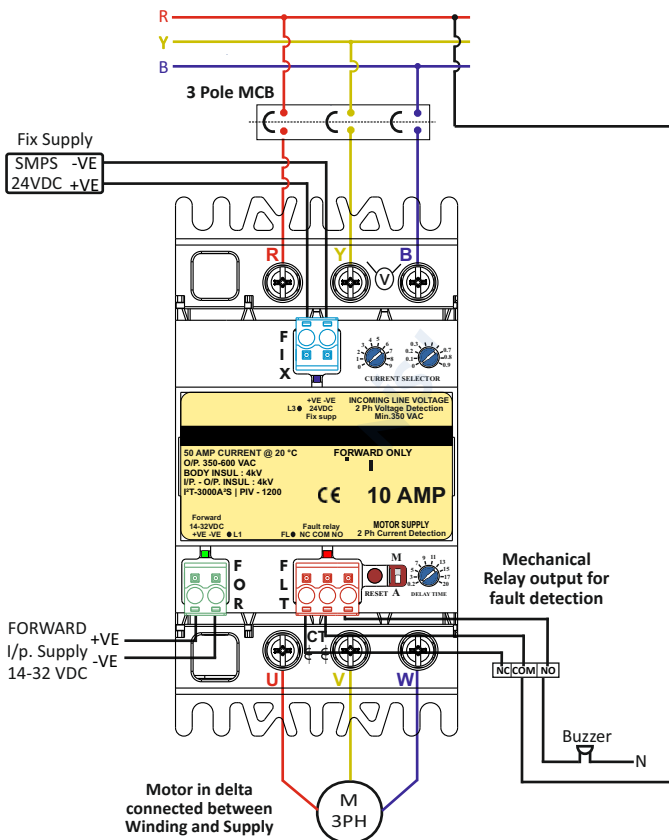

CONVENTIONAL CONNECTION

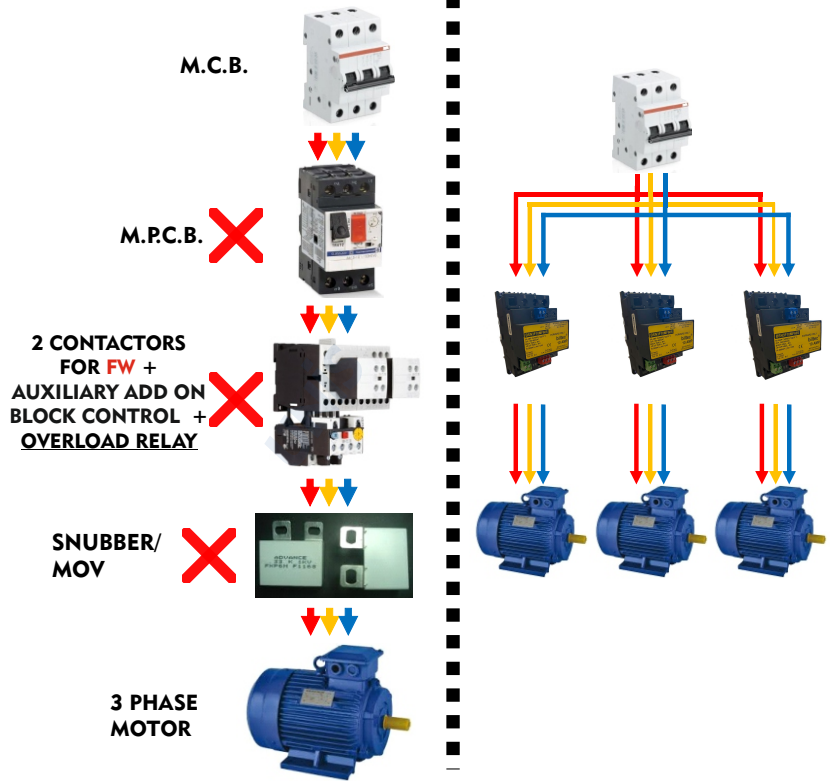

HEAT SINK TYPE "D-67.5" + DIN RAIL

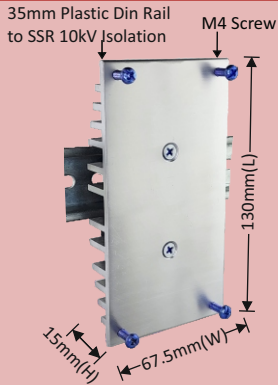

TYPE "D-67.5"
Model 301 - 1 Nos
Current upto 36 Amp @40°C
with Din Rail 42mm
 $\Delta T = 75^\circ C$
Surface Area:
 $750mm^2 \times 67.5mm$
 $= 50625mm^3$
67.50mm(W) X 130mm(L)
X 15mm(H) + SSR
Weight : @ 160gms

HEAT SINK TYPE "D-136" + DIN RAIL

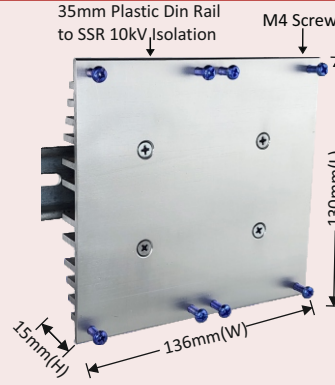

TYPE "D-136"
Model 301 - Upto 2 Nos
Current upto
65 Amp @40°C
with Din Rail 42mm
 $\Delta T = 75^\circ C$
Surface Area:
 $750mm^2 \times 136mm$
 $= 102000mm^3$
136mm(W) X 130mm(L)
X 15mm(H) + SSR
Weight : @ 320gms

HEAT SINK TYPE "D-204" + DIN RAIL

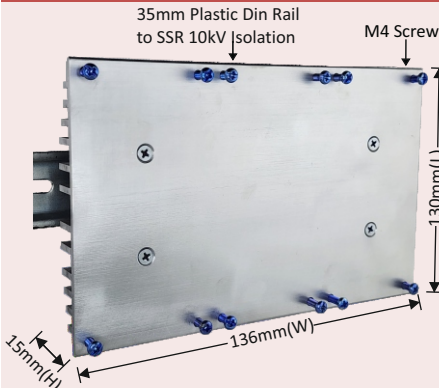

TYPE "D-204"
Model 301 - Upto 3 Nos
Current upto 95 Amp @40°C
with Din Rail 42mm
 $\Delta T = 75^\circ C$
Surface Area:
 $750mm^2 \times 204mm$
 $= 153000mm^3$
204mm(W) X 130mm(L)
X 15mm(H) + SSR
Weight : @ 440gms

HEAT SINK TYPE "D-272" + DIN RAIL

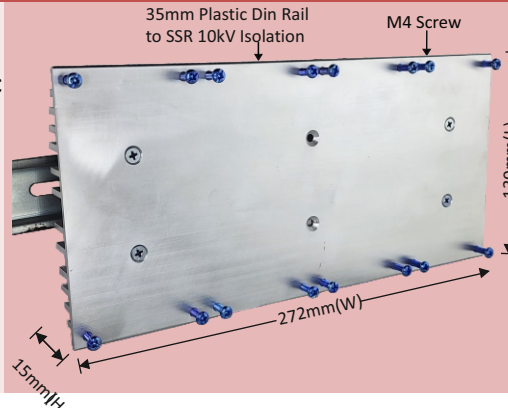

TYPE "D-272"
Model 301 - Upto 4 Nos
Current upto
125 Amp @40°C
with Din Rail 42mm
 $\Delta T = 75^\circ C$
Surface Area:
 $750mm^2 \times 272mm$
 $= 204000mm^3$
272mm(W) X 130mm(L)
X 15mm(H) + SSR
Weight : @ 580gms